

KBHR12900 12V 90Ah



The Kaise HR batteries were specially designed for applications that demand a very high energy output. With an optimized design of the grids and an excellent formula for pasting the plates, the HR series can deliver up to 40% more than the standard series.



Performance Characteristics

Nominal Voltage	12V	
Dimensions	Length (mm / inch)	306 / 12.0
	Width (mm / inch)	169 / 6.65
	Height (mm / inch)	210 / 7.91
	Total Height (mm / inch)	215 / 8.46
Approx Weight	(Kg / lbs) 28.5 / 62.8	
Design Life	10 years	
Terminal	M6	
Container Material	ABS	
Rated Capacity	4000Watts / Cell	(15min, 1.67V / cell, 25°C / 77°F)
	94Ah/4.70A	(20hr, 10.8V / cell, 25°C / 77°F)
	90Ah/9.0A	(10hr, 10.8V / cell, 25°C / 77°F)
Max. Discharge Current	800A (5s)	
Internal Resistance	Approx 4.4mΩ	
Operating Temp. Range	Discharge: -20 ~ 60°C (-4 ~ 140°F)	
	Charge: -10 ~ 60°C (14 ~ 140°F)	
	Storage: -20 ~ 60°C (-4 ~ 140°F)	
Nominal Operating Temp. Range	25 ± 3°C (77 ± 5°F)	
Cycle Use	Initial Charging Current less than 27A.	
	Voltage: 14.4V ~ 15.47V at 25°C (77°F)	
	Temp. Coefficient: -30mV/°C	
Standby Use	No limit on Initial Charging Current Voltage	
	13.4V ~ 13.8V at 25°C (77°F)	
	Temp. Coefficient: -20mV/°C	
Capacity affected by Temperature	40°C (104°F)	103%
	25°C (77°F)	100%
	0°C (32°F)	86%
Self Discharge	Fully charged Kaise High Rate Series batteries may be stored for up to 6 months at 25°C (77°F) and then a freshening charge is required. For higher temperatures the time interval will be shorter.	

Discharge Constant Current (Amperes) at 77°F (25°C)

Volts/cell	5min	10min	15min	20min	25min	30min	45min	1h
1.80V	303	225	188	149	131	116	18.7	50.3
1.75V	323	235	194	159	140	119	80.0	58.4
1.70V	335	242	200	163	143	125	82.0	62.0
1.67V	355	251	210	170	149	130	94.6	64.5
1.60V	365	280	215	178	156	141	95.0	67.8

Dimensions and Terminal (Unit: mm (inches))

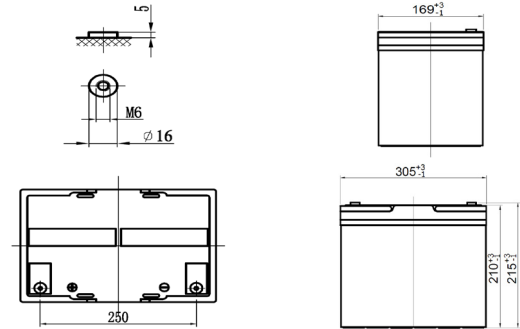

Applications

UPS
High power backup supply
Electric facilities
Power tools

Certifications

ISO 9001:2008 ISO 14001:2008



Discharge Current vs. Discharge Voltage

Final discharge voltage V/CELL	1.8	1.75	1.7	1.6
Discharge current (A)	$I \leq 0.1CA$	$0.25CA \geq I > 0.1CA$	$0.55CA \geq I > 0.25CA$	$I > 0.55CA$

Discharge Constant Power (Watts per cell) at 77°F (25°C)

Volts/cell	5min	10min	15min	20min	25min	30min	45min	1h
1.80V	540	428	344	287	252	210	151	115
1.75V	580	454	358	299	263	215	156	119
1.70V	611	468	390	303	266	222	162	126
1.67V	640	473	400	315	277	231	172	130
1.60V	685	500	412	332	292	240	178	134

(Note) The above characteristics data are average values obtained within three charge/discharge cycles not the minimum values.

Charging Characteristics (cycle use)

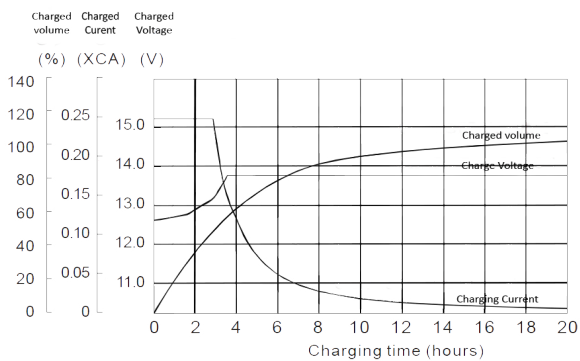

Effect of Temperature on Long Term Float Life

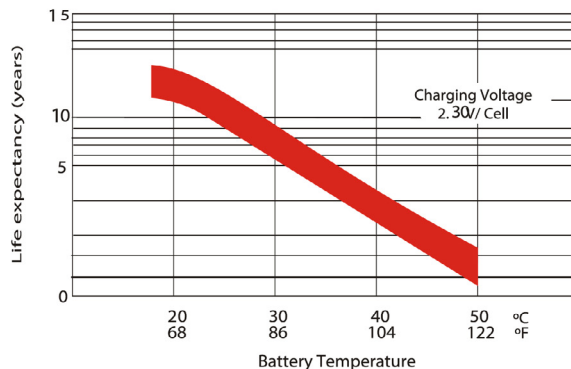

Temperature Effects in Relation to Battery Capacity

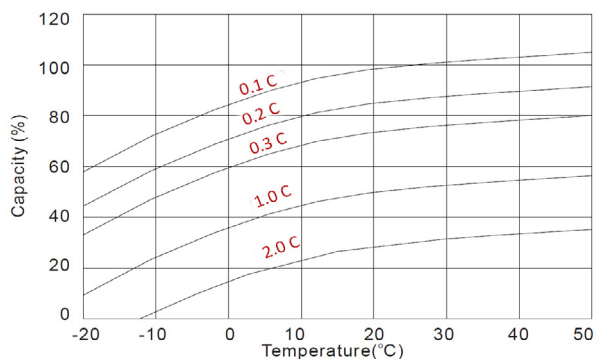

Self Discharge Characteristics

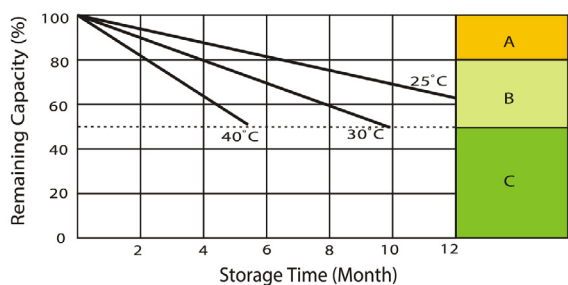

- A** With switch regulator (two-step controller) charge on curve max. charge voltage for max. 2 hrs/ day then switch over to continuous charge.
- B** Standard charge without switching.
- C** Boost charge (Equalizing charge with external generator) charge on curve continuous charge for max. 5 hrs/month, then switch over to curve Standard charge.

IMPORTANT NOTE: The specifications presented herein are subject to revision without notice.