

HTB-F Series High Temperature Batteries

HTB-600F

Narada's HTB-F series battery special designed for high temperature floating application with good cycling performance, idea for telecom service where the temperature is higher. With innovative structure design, high quality manufacturing and high quality high-temperature-resistant material, HTB-F batteries have 10 years design life at 35°C. HTB-F series also meet the standard <YD/T2657-2013 High temperature valve-regulated lead acid batteries for telecommunications>.



Specifications

Battery Model	HTB-600F	
Nominal voltage	2V	
Capacity	600Ah (10HR ,60A, 1.80V, 25°C)	
Approx.Weight	37.5kg	
Internal Resistance	Approx 0.28mΩ	
Max Charge Current Allowed	150A	
Charge Voltage (25°C)	Cycle use	Float use
	2.35V/cell	2.27V/cell
Temperature Ranges	Operation(Discharge): -40°C to 65°C (-40°F to 149°F)	
	Operation(Charge): -20°C to 65°C (-4°F to 149°F)	
	Storage: -20°C to 40°C (-4°F to 104°F)	
Terminal	M8 Female	
Terminal Hardware	15 ± 1.0 N.m	
Container Material	ABS (V0 optional)	

Dimensions (mm)

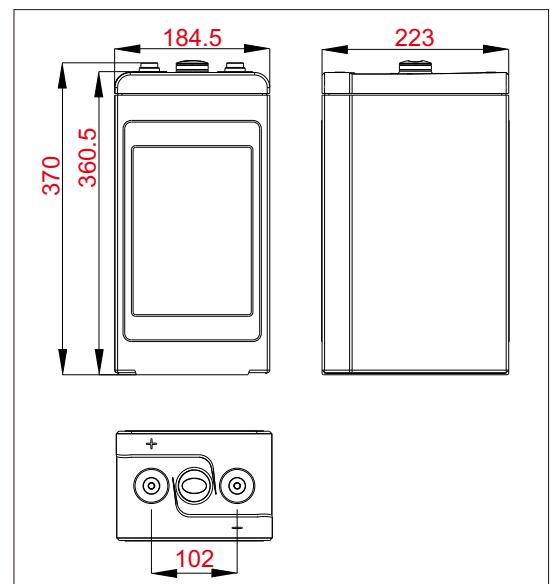

Constant Current Discharge Data Units: Amperes (25°C, 77°F)

End voltage per cell	15min	20min	30min	40min	50min	1h	2h	3h	5h	8h	10h
1.65V	720	670	540	480	430	338	205	157	102	72.0	64.0
1.70V	690	630	510	450	410	335	202	155	100	70.0	63.0
1.75V	630	540	480	420	390	333	200	152	98	68.0	62.0
1.80V	560	490	450	380	350	331	198	151	96	66.0	61.0

Constant Power Discharge Data Units: Watts per cell (25°C, 77°F)

End voltage per cell	15min	20min	30min	40min	50min	1h	2h	3h	5h	8h	10h
1.65V	1360	1200	1040	880	780	650	430	340	240	172	150
1.70V	1230	1160	980	850	740	630	410	320	220	154	140
1.75V	1180	1100	910	800	710	610	400	310	205	140	130
1.80V	1060	980	840	740	640	590	380	290	195	132	120

Discharge Voltage vs Time Curve (25°C)

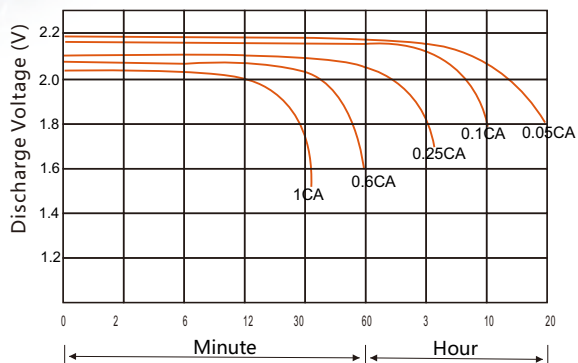

Charge Curve (25°C)

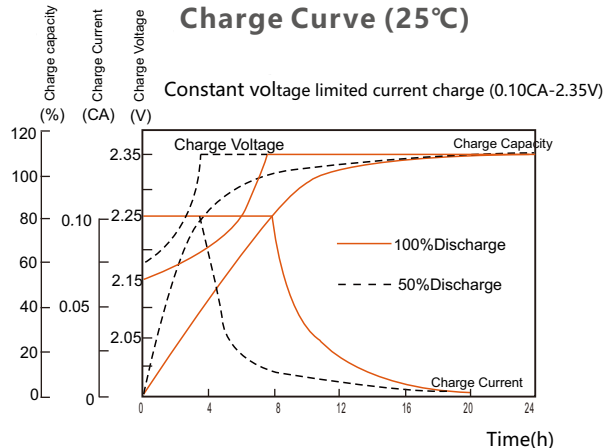

Capacity vs temperature curve

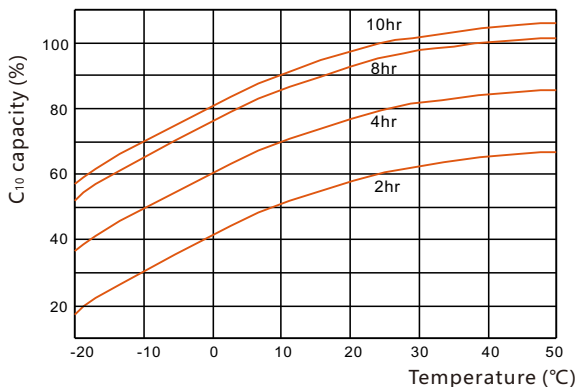

Residual Capacity vs Storage Time

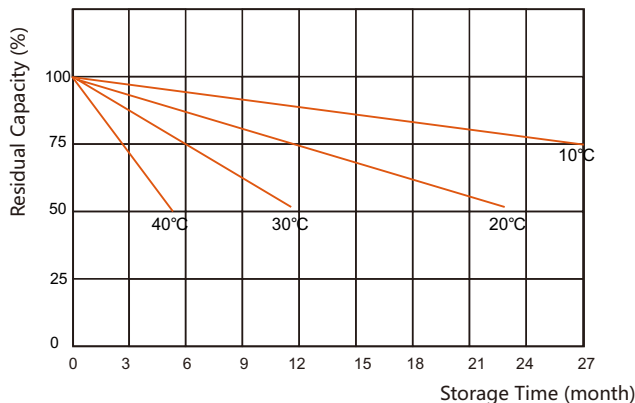

Capacity vs OCV curve

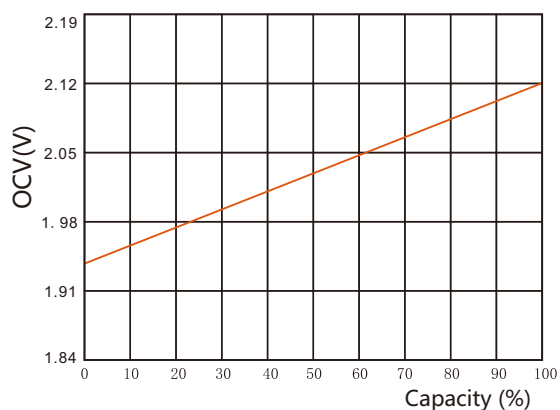

High temperature deep cycle life @ 55°C

