

KBHR12820 12V 82Ah



The Kaise HR batteries were specially designed for applications that demand a very high energy output. With an optimized design of the grids and an excellent formula for pasting the plates, the HR series can deliver up to 40% more than the standard series.



Performance Characteristics

Nominal Voltage	12V		
Dimensions	Length (mm / inch)	260 / 10.24	
	Width (mm / inch)	168 / 6.61	
	Height (mm / inch)	208 / 8.19	
	Total Height (mm / inch)	211 / 8.31	
Approx Weight	(Kg / lbs)	24.0 / 52.92	
Design Life	10 years		
Terminal	M6		
Container Material	ABS		
Rated Capacity	324.6Watts / Cell	(15min, 1.67V / cell, 25°C / 77°F)	
	82.0Ah	(20hr, 1.80V / cell, 25°C / 77°F)	
Max. Discharge Current	1230A (5s)		
Internal Resistance	Approx 4.5mΩ		
Operating Temp. Range	Discharge: -15 ~ 55°C (5 ~ 131°F)		
	Charge: 0 ~ 40°C (32 ~ 104°F)		
	Storage: -15 ~ 40°C (5 ~ 104°F)		
Nominal Operating Temp. Range	25 ± 3°C (77 ± 5°F)		
Cycle Use	Initial Charging Current less than 24.6A.		
	Voltage: 14.4V~15.0V at 25°C (77°F)		
	Temp. Coefficient: -30mV/°C		
Standby Use	No limit on Initial Charging Current Voltage		
	13.5V ~ 13.8V at 25°C (77°F)		
	Temp. Coefficient: -20mV/°C		
Capacity affected by Temperature	40°C (104°F)	103%	
	25°C (77°F)	100%	
	0°C (32°F)	86%	
Self Discharge	Fully charged Kaise High Rate Series batteries may be stored for up to 6 months at 25°C (77°F) and then a freshening charge is required. For higher temperatures the time interval will be shorter.		

Discharge Constant Current (Amperes) at 77°F (25°C)

Volts/cell	10min	15min	30min	1h	3h	5h	10h	20h
1.80V	158.9	138.1	89.5	52.9	21.4	13.9	7.86	4.10
1.75V	178.4	150.2	93.3	54.3	21.9	14.2	8.00	4.17
1.70V	193.4	160.1	98.1	55.9	22.4	14.6	8.14	4.24
1.67V	210.6	171.2	102.3	57.5	22.8	14.8	8.28	4.31
1.60V	227.3	180.7	106.3	58.8	23.1	15.1	8.43	4.36

Dimensions and Terminal (Unit: mm (inches))

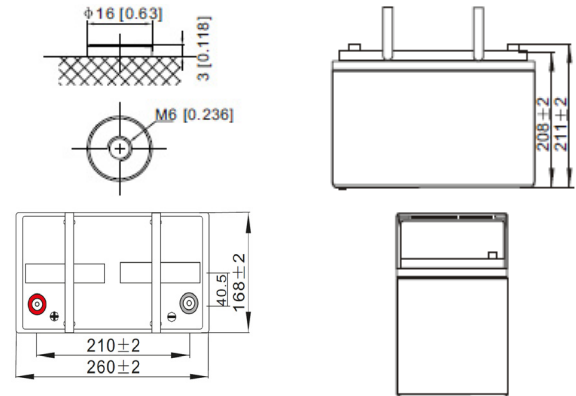

Applications

UPS
High power backup supply
Electric facilities
Power tools

Certifications

ISO 9001:2008 ISO 14001:2008



Discharge Current vs. Discharge Voltage

Final discharge voltage V/CELL	1.8	1.75	1.7	1.6
Discharge current (A)	$I \leq 0.1CA$	$0.25CA \geq I > 0.1CA$	$0.55CA \geq I > 0.25CA$	$I > 0.55CA$

Discharge Constant Power (Watts per cell) at 77°F (25°C)

Volts/cell	10min	15min	30min	1h	3h	5h	10h	20h
1.80V	307.7	269.0	176.4	105.2	42.9	28.1	16.1	8.42
1.75V	342.2	290.0	182.2	107.2	43.7	28.6	16.3	8.53
1.70V	366.8	305.4	189.6	109.5	44.4	29.1	16.5	8.61
1.67V	396.5	324.6	196.7	112.0	44.9	29.4	16.7	8.72
1.60V	423.4	339.1	202.3	113.5	45.1	29.7	16.8	8.73

(Note) The above characteristics data are average values obtained within three charge/discharge cycles not the minimum values.